

ATS 5 TRAILER



The ATS 5 Trailer is compatible with the following products:

- Shield 15 (Sh15) Radar Speed Display
- SpeedAlert 18 or 24 (SA18 and SA24) Radar Message Sign
- InstAlert 18 or 24 (IA18 and IA24) Variable Message Sign
- 5' minimum to bottom of sign

Features

- 620 lbs with 225Ah battery capacity and SpeedAlert/InstAlert 18
- 760 lbs with 450Ah battery capacity SpeedAlert/InstAlert 24
 - o Add 130 lbs for additional battery pair (145 lbs for AGM)
 - o Add 60 lbs for 120W solar panel
 - o Add 40 lbs for 65W solar panel
- **Tongue weight:** 20 lbs
- **Dimensions:** 61.5 inches long x 62.5 inches wide x 64 inches high (stowed)
- Simple manual lever lift system for one-person setup
- Removable tongue for 2-inch ball, lockable
- Storage for tongue and lift bar in locked battery compartment
- 16 ga. steel locking battery compartment with vented battery chamber, charger/accessories chamber and 1/8-inch aluminum diamond plate lid
- Continuous-weld steel frame, white marine grade powder coat finish
- **Wheels:** 12 inches, five-bolt steel rims with 4.5-inch bolt circle
- Replaceable steel fenders, weight supporting
- Locking wheel lug bolts, one per wheel, with removal tool
- **Axle:** 2000-lb leaf spring
- **Ground Clearance:** 9.75 inches under axle, 19 inches under chassis
- **Jacks:** 4, retractable crank type, fully adjustable at each corner, 1500-lb capacity each

- Recessed tail lights and DoT-approved lighting
- Safety chains, 30 inches with hooks
- DoT-approved red/white reflective tape
- License plate holder with light

Power

- 12 VDC system, standard four pin wiring plug
- 225Ah or 450Ah batteries, (2) 6VDC batteries in series, deep cycle marine (130 lbs per pair, two pair max)
- 20A time delay fuse on battery supply
- 120W solar assist with 10A solar controller to prevent overcharging, other solar wattages available
- Solar panels charge while sign stowed or deployed
- 10A 120VAC automatic charger with externally accessible AC connection
- Switch to control power to sign

Options

- 30 in x 36 in speed limit sign and interchangeable digits for 5-65 mph display and locking hitch pin for display and stowing; digit storage in battery compartment
- Red and Blue violator strobe light bar, set to flash above user set speed
- Low voltage disconnect solar controller to turn off sign if power falls below 11.5VDC (decreases run time)
- 2 and 5/16-in ball or pintle hook, adjustable height, on removable tongue
- Orange powder coat finish (minimum order quantity)
- AGM sealed batteries for lower temperature use, -40F (185Ah per pair, 370Ah max)
- Tamper alarm with adjustable sensitivity
- Wheel lock bar
- 14-inch wheels and fenders
- Speed-dependent messaging option

Warranty

- 1-year warranty (three months on batteries)

Compatible with these ATS Products

1. SpeedAlert 24 (optional light bar)
2. SpeedAlert 18
3. InstAlert 18
4. InstAlert 24
5. Shield 15



ATS Trailer: Deployed with SpeedAlert 24

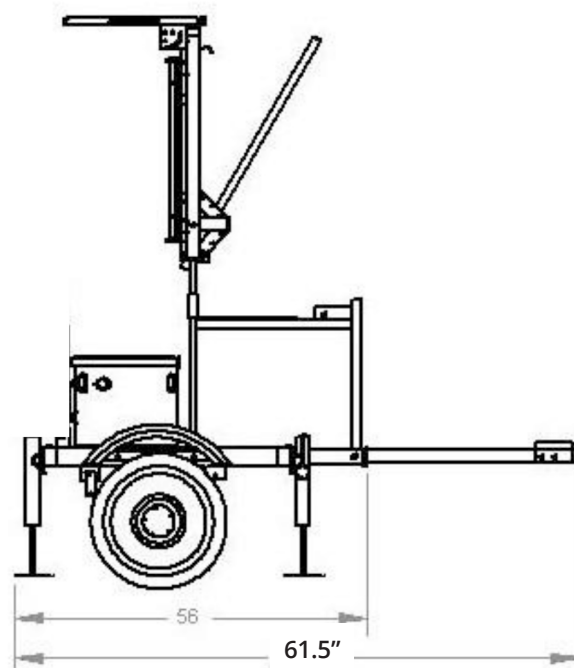
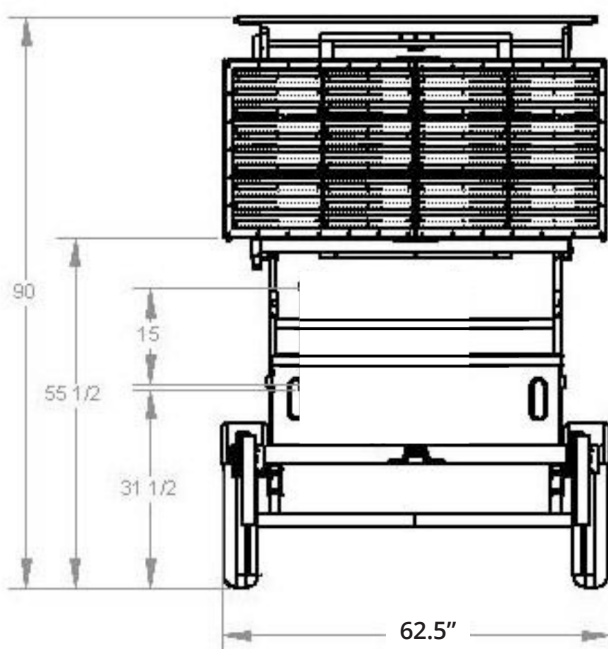

ATS Trailer: Stowed with SpeedAlert 24

