



INSTALERT 18 VARIABLE MESSAGE SIGN

Introduction

- InstAlert 18: 18"x28" full matrix (InstAlert 24: 24"x60" full matrix also available – see separate InstAlert 24 spec sheet)
- Size and weight without battery 30"x20"x2.74"
- Weight: 29 lbs.
- Full matrix display
- Universal Mounting System: Attach to pole, trailer or vehicle hitch mount
- Meets MUTCD specifications

InstAlert Operation Modes

- Message Mode: Display one message, up to six (6) screens
- All Messages: Sequence all messages in sign memory
- Schedule: Change message and/or mode up to 13 times per day
- Sign returns to last configuration when power is applied

InstAlert Programming Methods

Onboard programming (standard on all units):

- Select operation mode
- Select message from sign memory

TraffiCloud Web-based Remote

Management Services

Remote management using integral cell modem
(See *TraffiCloud specification for more information*):

- Turnkey system: Remote connectivity functional upon ship. Unit connects to TraffiCloud Service when powered
- Fully hosted web-based management system internet-connected computer with browser provides anywhere access on all connected devices



- No IT involvement or support necessary. System bypasses customer network, eliminating access issues Cellular provided by ATS, no separate cellular charges
- Hosted database requires no setup or maintenance by customer

Apps – All Apps included in TraffiCloud Message Suite

- Equipment Management: Online sign management — Change messages and settings remotely
- Alerts: Notifications for low battery and tampering
- Mapping: Visually managed equipment and data

Engineered and manufactured in the United States of America



InstAlert 18 on portable pole



InstAlert 18 on ATS Trailer

ATS PC Sign Manager

Local Management using PC with USB connection standard with all signs, Bluetooth optional

- PC based client software
- Connect to sign via USB or Bluetooth (Optional)
- ATS Android App: *Local Management (Optional)*:
- Android OS wireless Bluetooth control local to unit
- Android device can be phone or WiFi device with Bluetooth

Local Management Features (PC and Android)

- Create and change messages and settings
- Manage all unit settings, automatic sync with TrafficCloud Web-based Remote Management Service if subscribed
- All messages saved for online management and backup
 - Create message and save to TrafficCloud library messages available on all ATS Android App or PC Sign Manager devices with TrafficCloud subscription

InstAlert Messages

IA18: 1-2 line message

- 1 Line: 10 ¼" (H) x 5.75" (W) characters, four (4) per line
- 2 Lines: 7" (H) x 4" (W) characters, six (6) per line
- Up to six screens per message
- Full graphics capability, each LED individually controllable
- Variable display time, flash and reverse rates for each screen
- Scroll through 25 user defined onboard messages using selector buttons built into sign, no training necessary
- Ability to sequence messages for up to 144 screen animation
- Message power efficiency calculator in software
- Actual sign preview and unlimited message storage using TrafficCloud Web-based Remote Management Service, ATS PC Sign Manager or ATS Android app
- Messages on sign retained when power removed
- Sign returns to last message when power applied
- Conditional Messaging – Dynamically display message driven off sensors and/or incorporate into messages

InstAlert Programming

Configure the following parameters via TrafficCloud Web-based Management System, ATS Android App or PC Sign Manager

- Messages:
 - Create and load message using “Display Now” feature
 - Load 24 messages into sign’s memory
 - Scroll messages in sign’s memory
 - Display signs stored in TrafficCloud Web, ATS Android app or PC Sign Manager

Scheduling

- All Days, Multiple Messages: Schedule up to 50 different messages or modes for up to 13 different time periods in a 24 hour day, repeats in each 24 hour cycle
- Seven Day, Multiple Messages: Schedule different messages or modes for up to 13 different time periods in each 24 hour day for each of seven days, repeats in each seven day cycle; up to 50 different messages can be used over the seven day period
- All messages and scheduling reside on the sign – no external hardware necessary
- Program schedule via TrafficCloud Web, ATS Android app or ATS PC Sign Manager, save to load onto multiple signs
- Internal real-time clock, time and schedule maintained with power disconnected

Construction

- LED Pixels: Amber 595nm, 30-degree viewing angle, 100,000 hours, black background, (MUTCD compliant)
- LED Density: 0.6"x1" pitch, 18x48 pixel matrix
- Conformal coating on all circuit boards
- Integral handle
- Weatherproof, NEMA 4, IP65 sealed
- ¼" Tinted, non-glare, UV stabilized polycarbonate face
- Drip proof, vented battery compartments (2)

- Aluminum chassis, 14 ga, white powder coat finish, black powder coat front for maximum contrast for display visibility
- Tamper resistant mounting hardware system, hardware, controls and battery access secured behind enclosure lock
- -40 to 160F operating temperature range, 95% humidity non-condensing (-20F for Bluetooth communication, 5F for internal camera)

InstAlert Power

- Max Power Input: 12VDC, 3A max, 36W max
- Power saving circuitry and automatic dimming for ambient light conditions with adjustable dimming range and manual display brightness override
- InstAlert 18 Power Options:
 - 16Ah LFP battery with built-in short circuit and reverse polarity protection circuitry; 1.5A 12.8VDC output, 120VAC input automatic charger; Capacity for up to two (2) batteries in unit for extended portable use
 - External Solar System: 50W or 90W solar panel and bracket, Solar controller panel with 26Ah lead acid battery; 6A 120VAC automatic charger optional
 - Integrated Solar System: 50W or 90W solar panel and bracket, solar controller panel with two 16.5AH lithium batteries
 - 100-220VAC AC power supply (6A 12VDC) in external NEMA 4 enclosure
- ATS 5 Trailer (batteries with optional solar assist):
 - 235Ah or 470Ah battery system, 40W or 60W solar option
- ATS 3 Trailer: 90W Solar panel with Integrated Solar Sign
- Battery level indicator on sign, ATS Android app, ATS PC Sign Manager or TrafficCloud Remote Management
- Auto recovery for battery with solar



InstAlert 18 (Left to Right: Left Side, Front, Back and Right Side Views)

Standard InstAlert System Components

- InstAlert 18 variable messaging
- Tamper resistant mounting plate and hardware
- Key
- On-board controls
- ATS PC Sign Manager software with USB cable

Optional InstAlert Components and Features

- TraffiCloud Web-Based Remote Management Service
- ATS Android app, Blue tooth connectivity
- Padded carrying case
- Extra mounting brackets
- 7A, 30VDC or 7A 120VAC max, 100mA 5VDC min, no power supplied, simply a contact closure
Tamper Alarm: ATS 5 or ATS 3 Trailer

InstAlert Mounting Options

- Pole mount standard with included bracket, hardware
- NCHRP 350-approved on 4" pole (Letter SS-135)
- ATS 5 Trailer (refer to ATS 5 specifications for more information)
- ATS 3 Trailer (refer to ATS 3 Trailer specifications for more info)

- Vehicle Hitch Mount
 - Mounts sign 30" to bottom of sign from receiver tube (final height dependent on receiver height)
 - Fits 1 ¼" or 2" receiver, adapter included, ½" hitch pin
 - Locking rotation adjustment on 15 degree, increments over 180 degrees, +/- 5 degrees tilt
White powder coat finish with rear reflector
- Standard Folding Portable Post
 - Folds for easy storage and portability
 - **IA18:** 60" to 73" to bottom, 80" to 93" to top of sign depending on leg positions
- Mounting provisions for permanent applications with ¼–20 threaded holes

Warranty Options

- PremierCare Perpetual Warranty available with current TraffiCloud subscription. Ask your ATS sales rep for details.
- ATS 3-year Manufacturer's Warranty comes standard on all InstAlert variable message signs purchased after January 1, 2019.

InstAlert 18 Mounting Bracket and Mounting Holes

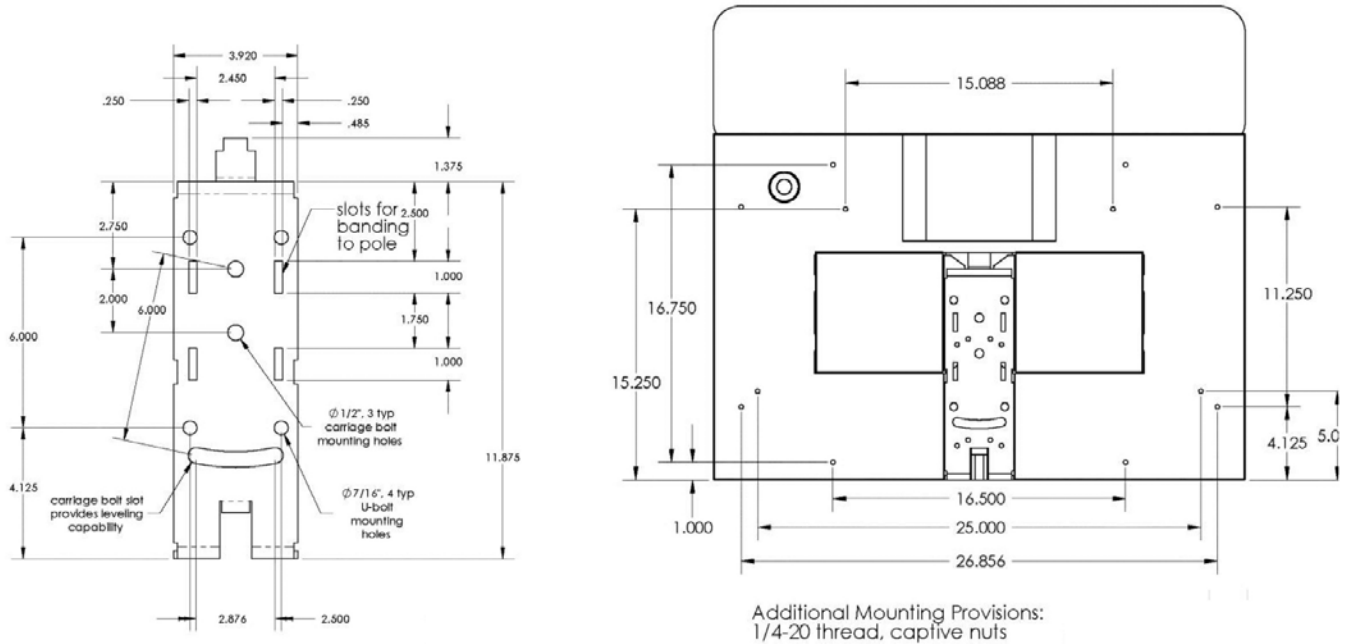

InstAlert 18 with Trailer Mounting Brackets Installed – For Installation on Existing Trailers for Trade In

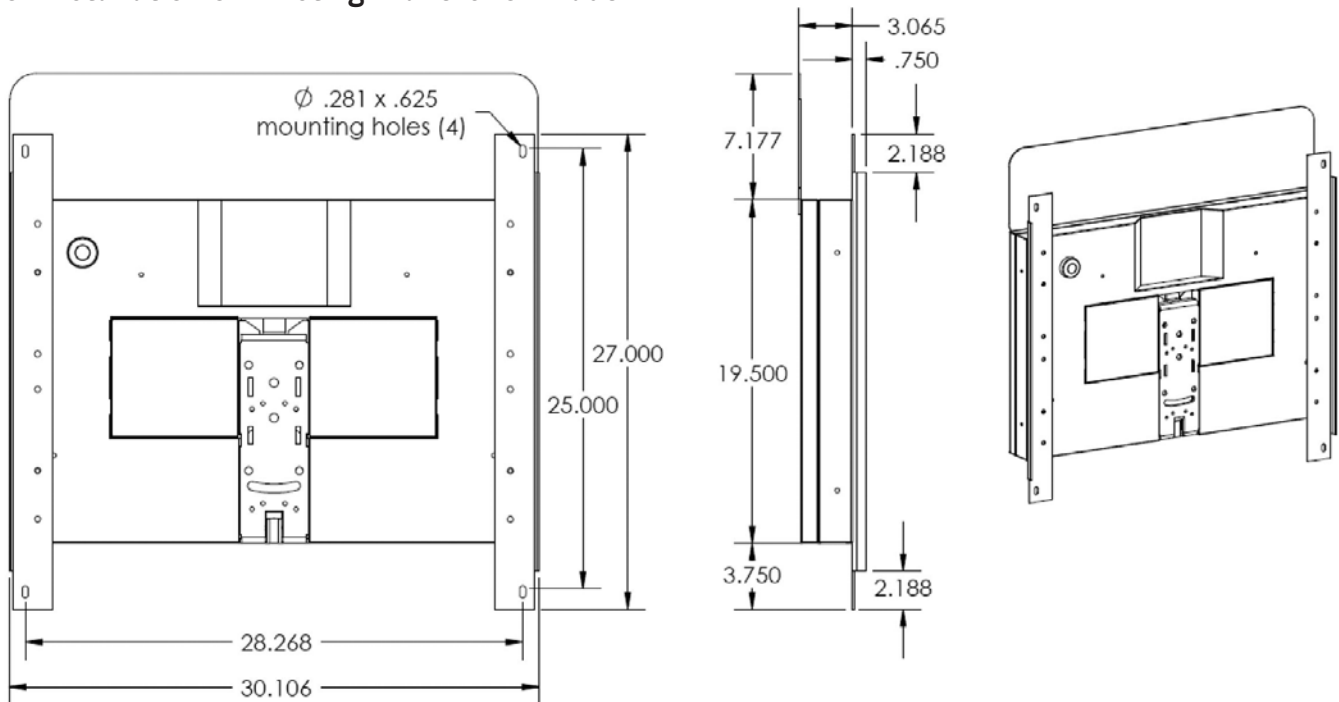

For more information visit us online

sales@alltrafficsolutions.com Call us at 866.366.6602

All Traffic Solutions, 14201 Sullyfield Circle, Suite 300, Chantilly, VA 20151

©All Traffic Solutions TraffiCloud leverages our patented technology (US Patents 8417442; 8755990; 9070287; 9411893) to deliver unique cloud-based management, features and functionality. TraffiCloud is a registered trademark of All Traffic Solutions.

ALL TRAFFIC
SOLUTIONS

