



PRODUCT SPECIFICATIONS:

ATS-5 TRAILER

ATS-5 Trailer is compatible, interchangeably, with the following products:

- o Shield 15 (Sh15) Radar Speed Display
- o SpeedAlert 18 or 24 (SA18 or SA24) Radar Message Sign
- o InstAlert 18 or 24 (iA18 or iA24)

Variable Message Sign

- 5' minimum to bottom of sign

Weight

- o 620# with 235Ah battery capacity and SA18
- o 760# with 470Ah battery capacity instALERT
- o Add 130# for additional battery pair
- o Add 60# for 120W solar panel
- o Add 40# for 65W solar panel
- **Tongue weight:** 20 pounds
- **Dimensions:** 61.5" long x 62.5" wide x 64" high (stowed)
- Simple manual lever lift system for 1 person setup
- Removable tongue for 2" ball, lockable
- Storage for tongue and lift bar in locked battery compartment
- 16 ga. steel locking battery compartment with vented
- battery chamber, charger/accessories chamber and 1/8" aluminum diamond plate lid
- Continuous weld steel frame, White marine grade powder coat finish
- **Wheels:** 12", 5 bolt steel rims with 4.5" bolt circle
- **Ground clearance:** 9.75 under axle, 19 under chassis
- Replaceable steel fenders, weight supporting
- Locking wheel lug bolts, 1 per wheel, with removal tool
- **Axle:** 2000# leaf spring
- **Jacks:** 4, Retractable crank type, fully adjustable at each corner, 1500 lb capacity each
- Recessed tail lights and DOT approved lighting

- Safety chains, 30" with hooks
- DOT Approved red/white reflective tape
- License plate holder with light

ATS-5 Trailer Power

- 12 VDC system, Std 4 pin wiring plug
- 235Ah or 470Ah batteries, (2) 6VDC batteries in series, deep cycle marine (130 lbs per pair, 2 pair max)
- 20A time delay fuse on battery supply
- 65W solar assist with 10A solar controller to prevent overcharging, other solar wattages available
- Solar panels charge while sign stowed or deployed
- 10 Amp 120VAC automatic charger with externally accessible AC connection
- Switch to control power to sign

ATS-5 Trailer Options

- 30" x 36" speed limit sign and interchangeable digits for 5-65 mph display and locking hitch pin for display and stowing; digit storage in battery compartment
- Red and Blue Violator Strobe Light Bar, set to flash above user set speed
- Low Voltage Disconnect solar controller to turn off sign if power falls below 11.5VDC (decreases run time)
- 2 5/16 ball or pintle hook, adjustable height, on removable tongue
- Orange powder coat finish (minimum order qty)
- AGM sealed batteries for lower temperature use, -40F (185Ah per pair, 370Ah max)
- Tamper alarm with adjustable sensitivity
- Wheel lock bar
- '7' digit for speed limit sign
- 14" tires and fenders
- Speed Dependent Messaging Option

Warranty

- 1-year warranty (three months on batteries)

Compatible with these ATS Products

Engineered and manufactured in the United States of America

1. ATS-5 with SpeedAlert 24 and optional light bar
2. ATS-5 with SpeedAlert 18



ATS-5 Trailer: Deployed with SpeedAlert 24

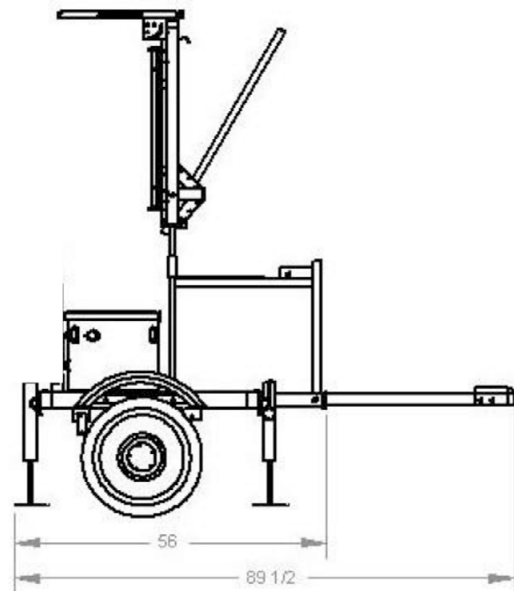
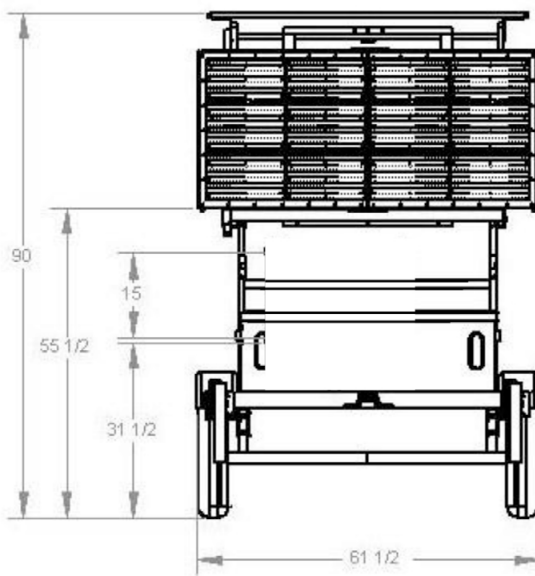

ATS-5 Trailer: Stowed with SpeedAlert 24

