



## PRODUCT SPECIFICATIONS:

# PARKTRAK PARKING COUNTING SYSTEM

- Count vehicles at entrances, exits and other defined parking areas
  - o Single lane counting
  - o Side or overhead mount
  - o Simple installation and setup
  - o Narrow sensing beam differentiates tailgating vehicles
  - o Accuracy >98%
- Directional sensing or simple count models
- Simple installation and configuration
  - o Automatic range detection for overhead installations
  - o Thresholds for minimum and maximum vehicle detection range
  - o Thresholds for minimum and maximum vehicle detection time to minimize invalid counts
  - o Beeper and LED indicators can be enabled to verify vehicle detection during installation
  - o Flexible configuration of parking collection entry and exits
- Connectivity
  - o Connects to TraffiCloud™ with integrated connectivity via cellular, WiFi or Ethernet
  - o Cellular connectivity is provided as a turnkey system
  - o Configure system through TraffiCloud
- Integrated with TraffiCloud
  - o Historical reports on usage and availability
  - o APIs for other systems to call data
  - o Set thresholds for availability determining FULL capacity display
  - o Configure parking collections from groups of sensors online
  - o Can accept and integrate inputs from other systems including loops, cameras, etc.
  - o Online count updates
- Usage, availability by time
- Entry and exit counts by time, peaks
- Log of count updates
  - o SDK for API calls to provide data to other systems
  - o Data can be stored on unit and downloaded locally, 30 days of storage

- Displays
  - o Integrate with ATS LED message signs to display availability in advance of parking facilities
  - o Configurable thresholds for availability determining FULL display
- Power
  - o 6W
  - o 100-130 VAC
  - o Solar power
    - o Battery backup options – short and long long term
- o System tracks counts during outage and uploads upon reconnection
- Packaging
  - o NEMA 4 Enclosure, IP67
  - o -20 to 140F operating range
  - o Self contained system, no other cabinets required
  - o Pole mount or roof mount
- Dimensions: 15.75" x 10" x 5"
- Weight: 15 pounds

**PARKTRAK PARKING COUNTING SYSTEM**



### PARKTRAK POLE MOUNT DIAGRAMS

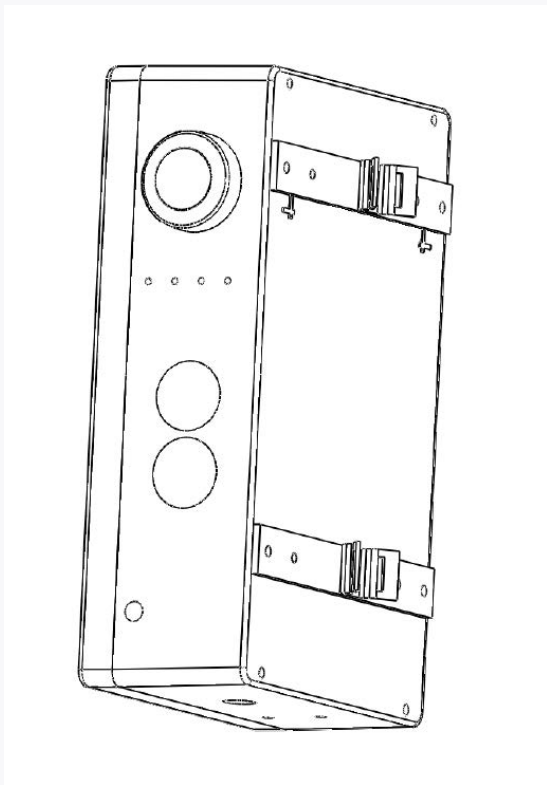

**SIDE MOUNT**

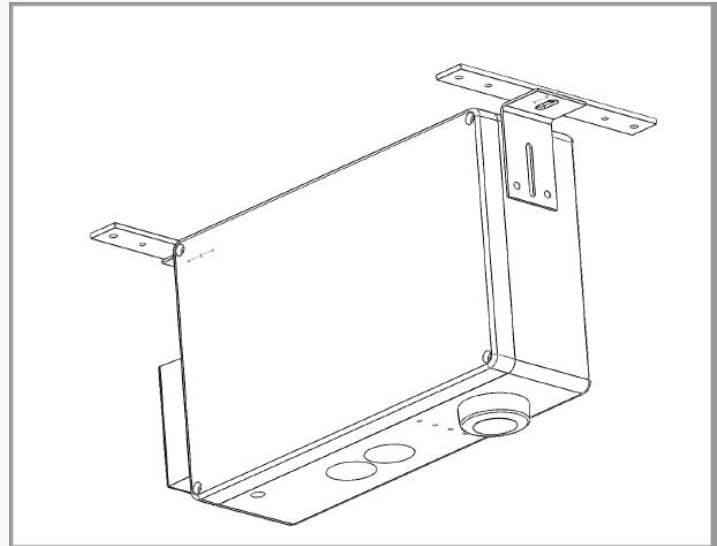

**TOP MOUNT**