



PRODUCT SPECIFICATIONS:

SHIELD RADAR SPEED DISPLAY

Shield Speed Display

- 3 units to cover any application
 - Shield 12 or 12B: 12" x 6" digits, 112 LED/digit
 - Shield 15 or 15B: 15" x 8" digits, 140 LED/digit
 - SpeedAlert 18: *See SpeedAlert 18 Specification*
- Size, Weight without battery
 - Shield 12: 15.5" x 13.5" x 3.12", 12 lbs
 - Shield 15: 24" x 17" x 3.12", 18 lbs
- **Universal mounting system:** attach to pole, trailer or vehicle hitch mount
- Integral camera for awareness and alert driven images
 - 640 x 480 daylight images (optional in Sh12B, Sh15B)
- **Radar:** K Band (24.15 GHz), FCC Certified, no license required, +-1mph accuracy, 11 degree square pickup area, 5-105mph (8-150 kph), range: 1200+ ft. (12B, 15B range: 400')
- Meets MUTCD Specifications

Shield Operation Modes

- **Speed Display:** Display approaching vehicle's speed and record traffic speed and volume data
- **Stealth or Display Off:** Collect traffic speed and volume data with no display
- Changeable speed limit sign
- **Dependent Message:** Send speed data to an InstAlert
- Variable Message Sign to display messages tailored to vehicle's speed
- **Schedule:** Change mode or speed limit up to 13 times/day
- Collect traffic data – vehicle volume by speed and time – in all modes
- Sign returns to last configuration when power applied

Shield Programming Methods

On-Board Programming (standard on all units)

- Set speed limit
- Set display mode

ATS PC Sign Manager Local Communication

(PC control/USB connection: Standard with on all signs)

- PC based client software
- Connect to sign via USB or Bluetooth (optional)

ATS Android App Local Communication (Optional):

- Android OS wireless Bluetooth control local to unit
- Android device can be phone or WiFi device with Bluetooth

Local Communication Features:

- Create and change modes and settings
- Local data retrieval and management
- Local image retrieval and management from internal camera
- Manage all unit settings, automatic sync with TraffiCloud web
- Based Management (optional)
- All traffic data can be saved for online management and backup
 - Retrieve data and save to TraffiCloud, generate limited reports online from hosted data

TraffiCloud™ Web-based Management Services using integral cell modem for remote management

(See TraffiCloud specification for more information):

- Turnkey system. Remote sign connection functional upon ship. Unit connects to TraffiCloud system when sign powered
- Fully hosted web-based management system
 - Internet-connected computer with browser provides anywhere access on all browser capable, connected devices

- o No IT involvement or support necessary. System bypasses customer network eliminating access issues
- o Cellular provided by ATS, no separate cellular charges.
- o Hosted database requires no setup or maintenance by customer

App

All apps included in Traffic Suite:

- o **Equipment Management:** Change messages and settings remotely, monitor sign online
- o **Reporting:** Online data retrieval and management, analysis and enhanced report generation
- o **Image Management:** Online image retrieval and management of images from internal camera
- o **Alerts:** Notifications for low battery and tampering, high speed and congestion, alerts can include images
- o **Mapping:** Visually manage equipment and data
- o **Premier Care:** Enhanced warranty and real-time monitoring

Shield Speed Programming

- Configure the following parameters via ATS PC Sign Manager, ATS Android App or TraffiCloud Web-Based Management Service (optional):
 - o Speed limit
 - o Maximum speed displayed
 - o Display on/off/specific mph activation
 - o Violator Alert on/off/specific mph activation
 - o Radar sensitivity (range)
- Speed limit sign operation
 - o Change speed limit up to six times per day
 - o Sign flashes when car passing over speed limit, blanks when car over maximum speed displayed
- Set time via PC or sync with cell signal
- Sign firmware field and remotely upgradeable

Scheduling

- **All days:** schedule up to six different modes for up to 13 different time periods in a 24 hour day, repeats in each 24 hour cycle
- **Seven days:** schedule up to six different modes for up to 13 different time periods in a 24 hour day for each of seven days, repeats in each seven day cycle
- All messages and scheduling reside on the sign – no external hardware necessary

- Schedules can be saved for loading on multiple signs
- Program schedule via TraffiCloud, ATS PC Sign Manager or ATS Android App
- Camera activation available in schedule options
- Internal real time clock, time and schedule maintained with power disconnected

Shield Data Logging Option

- Traffic data reporting using TraffiCloud Online Reporting App
- Collect data with TraffiCloud automatic service or local collection with ATS PC Sign Manager or ATS Android App with data saved to the TraffiCloud
- Reports include tables and charts to address all constituents with the most applicable data presentation
- All reports exportable to Excel, CSV and PDF
- Automatic Data Collection - TraffiCloud
 - o Data retrieval at least eight times per day – near real time reporting, memory never full
 - o All data in one database, available for analysis including compliance comparisons by location
 - o Access reports from interactive map view by location

Reports

- o Summary page with average and 85th percentile speed, average daily volume, 10-mph pace speed, high and low speed, display mode
- o Traffic counts by speed range, full day and time of day over selected date range with 5-mph resolution
- o Vehicle counts by time range per day by hour
- o Vehicle counts by speed range and time of day
- o Compliance by speed range with three ranges
- o Enforcement report showing highest speed and volume violators over selected locations where data collected
- **Local Data Collection:** ATS PC Sign Manager or Android App
 - o All data collected hosted in online TraffiCloud database for anywhere access
 - o Download traffic data from sign with USB or Bluetooth connection
 - o 30 days of high volume data minimum, data collection rolls over when memory reaches capacity

Compatible with these ATS Products

Engineered and Manufactured in the United States of America



Shield 12



Shield 15 mounted below speed limit sign



Shield 15 on portable post



Shield 15 on ATS 5 Trailer

Construction

- “YOUR SPEED” sign
 - o High intensity prismatic reflective background
 - o Shield 12: 15.5” x 13.5”
 - o Shield 15: 24” x 8”
 - o Sign stores for compact storage and protects sign face, thumbscrews and tamper proof hardware included
 - o 3.5” high MUTCD ‘C’ letters
- **LED pixels:** Amber 595nm, 30-degree viewing angle, 100,000 hrs, black background, (MUTCD compliant)
- Conformal coating on all circuit boards
- Integral handle

- Weatherproof, NEMA 4, IP65 sealed electronics compartment;
- Drip proof, vented battery compartments (2)
- 1/4” tinted, non-glare, UV stabilized polycarbonate face
- Entire face removable for service
- Tamper resistant mounting hardware pocket, hardware secured behind enclosure lock
- Aluminum chassis, 14 ga, white powder coat finish, black powder coat front for maximum contrast for digit visibility
- Protective polycarbonate corners also provide guide for YOUR SPEED sign storage
- -40 to 160 F operating temperature range, 95% humidity non-condensing (-20F for Bluetooth communication, 5F for internal camera)

Shield Power

- Power Input, Max:
 - o Shield 12: 12 VDC, 1.1 A, 15 W
 - o Shield 15: 12 VDC, 1.5 A, 20 W

- Power saving circuitry and automatic dimming for ambient light conditions with adjustable dimming range and manual display brightness override

All Shield units can be powered interchangeably with any of the following power options; unit can be outfitted to be powered by multiple sources selected in the field

- **Shield 12 and 15:** Capacity for two batteries in unit for extended portable use
 - 10.2Ah Lithium LFP Battery with built-in short circuit and reverse polarity protection circuitry, 1.5A 12.8 VDC output, 120VAC input automatic charger; Capacity for up to two batteries in unit for extended portable use
 - Solar panel assist: 40W or 60W solar panel and bracket, Solar controller panel w/18Ah or 26Ah lead acid battery, 6A 120VAC automatic charger optional
 - 100-220VAC AC power supply (6A 12VDC) in external NEMA 4 enclosure
- **Shield 15 only:** 16Ah Li-Ion LFP battery, for longer unattended portable use, Capacity for up to two batteries in unit for extended portable use
- **Shield 15 on trailer**
 - Trailer batteries – 100 or 235 Ah, solar option
 - Auto recovery with solar for low battery

Standard Shield System Components

- Shield Radar Speed Display
- Tamper resistant mounting plate and hardware
- Key
- Web based programming software for PC control with USB cable

Optional Shield Components and Features

- TraffCloud Web-based Remote Management System
- Padded carrying case
- Extra mounting brackets
- Violator Alert, 12 white LED flash to alert violators
- Metric display
 - Shield 12: 2-digit KPH display
 - Shield 15: 3-digit KPH display
- Fully compatible with Speed Dependent Messaging option when used with an InstAert Variable Message Sign - see Speed Dependent Message System section

- **Relay closure**
 - 7A, 30VDC or 7A 120VAC max, 100mA 5VDC min, no power supplied, simply a contact closure
 - Trigger relay at specified speed with configurable duration from 1 to 10 seconds per radar event

- Bullet resistant face
- **Tamper alarm:** ATS-5 trailer

Shield Mounting Options

- Pole mount standard with included bracket, hardware
 - NCHRP 350 approved on 4" aluminum pole (SS-135)
- ATS-5 Trailer (Shield 15 only, refer to ATS 5 specifications for more info)
- Vehicle Hitch mount
 - Mounts sign 30" to bottom of sign from receiver tube (final height dependent on receiver height)
 - Fits 1 1/4" or 2" receiver, adapter included, 1/2" hitch pin
 - Locking rotation adjustment on 15 degree increments over 180 degrees, +/- 5 degrees tilt
 - White powder coat finish
 - 24 x 30 speed limit sign and digits included for 5-65 mph speed limit signs
- Standard Folding Portable Post: (Sh12 and Sh15)
 - Folds for easy storage and portability
 - **Shield 12:** 60" to bottom, 73" to top, add 13" for upper leg position
 - **Shield 15:** 60" to bottom, 77" to top, add 13" for upper leg position

PremierCare Warranty

- 1-year warranty (three months on Li-Ion batteries)
- Available with TraffCloud subscription
 - Warranty service fully covered
 - Product software upgrades free
 - Vandalism and accidental damage (non-warranty) at 50% off list price

Shield 12 and 15 Mounting Bracket

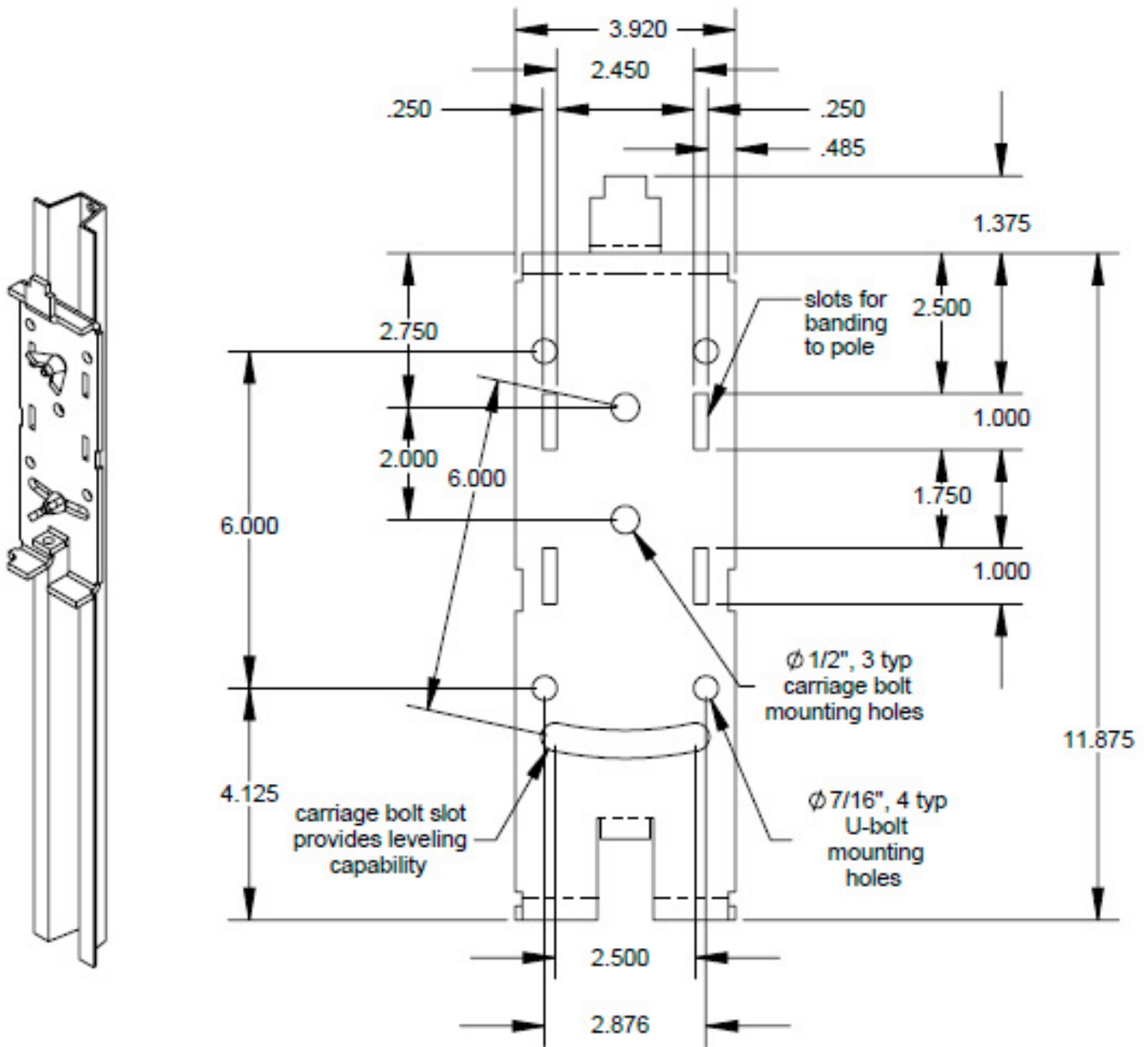

Shield 12 and 15 Dimensions

Dim	X	Y	Z	B	D	E	L	H
Sh12	15.5	13.5	3.13	26.3	5.75	12	15.5	13.5
Sh15	24	17	3.12	24.3	8	15	24	8

