



Product Specification instALERT Rapid Messenger Variable Message Sign

instALERT Variable Message Sign

- Open dimensions: 1 5/8" x 28" x 60"
- Folded dimensions: 3 1/4" x 28" x 30"
- Folded sign fits in police cruiser trunk, SUV hatch
- Full matrix display: 26 x 96 pixels, 0.6"x1" pitch
- LED pixels: Amber 595nm, 30 degree viewing angle, 100,000 hrs, black background, MUTCD compliant color, universal display modules
- Meets MUTCD Specifications
- On-board message selector buttons to select between 25 internal messages and modes with anti-tamper lockout
- Local and remote management and monitoring options
- Sign has integral active cell modem allowing TraffiCloud Web-Based Management Services for remote management
- Integral camera for awareness and alert driven images – 640x480 daylight images
- Power saving circuitry and automatic dimming for ambient light conditions with adjustable dimming range and manual display brightness override
- Conformal coating on all circuit boards
- Integral case handles and nylon web handles
- Weight: 43 pounds
- Weatherproof, inherently sealed design
- 1/8" tinted, non-glare, UV stabilized polycarbonate face
- Entire face removable for service
- Aluminum chassis, 12 ga., with black powder coat finish
- Mounting provisions for permanent applications, (12) 1/4"-20 threaded holes
- -40 to 160 F operating temperature range, 95% humidity, non-condensing (-20F for Bluetooth comm.)
- Withstands 70 mph winds

instALERT Operation Modes

- Message Mode: Display one message, up to 6 screens
- All Messages: Sequence all messages in sign memory
- Schedule: Change message and/or mode up to 13 times/day
- Speed based modes available in the SpeedAlert 24 configuration
- Sign returns to last configuration when power applied

instALERT Messages

- 1-3 line messages
 - 1 line: 24" H x 12.5" W characters, 4 per line
 - 2 lines: 10 1/4" H x 5.75" W characters, 8 per line
 - 3 lines: 7" H x 4" W characters, 12 per line
 - 2 lines: (1) 7" char, 12/line, (1) 10 1/4" char, 8/line
- Up to 6 screens per message
- Message power efficiency calculator in software



- Variable display time, flash and reverse rates for each screen
- Full graphics capability, each LED individually controllable, programmable from PC, PDA or remotely
- Ability to link multiple messages for up to 144 screen animation
- Scroll through 25 user defined onboard messages using selector buttons built into sign, no training necessary; buttons on unit become inactive after timeout to prevent tampering, reactivate by reapplying power
- Unlimited message storage on PC, Android device or remote server
- Messages on sign do not get erased when power removed
- Sign returns to last message when power applied
- Actual sign preview on PC, Android or TraffiCloud

instALERT Programming

Program and monitor the sign three ways:
On-Board Programming (standard on all units)

- Select message from sign's memory
- Select operation mode

TraffiCloud Web-Based Management Services using integral cell modem for remote management (See TraffiCloud specification for more information):

- Turnkey system. Remote sign connection functional upon ship. Unit connects to TraffiCloud system when sign powered
- Fully hosted web-based management system



- Internet connected computer with browser provides anywhere access on all browser capable, connected devices.
- No IT involvement or support necessary. System bypasses customer network eliminating access issues
- Cellular provided by ATS, no separate cellular charges.
- Hosted database requires no setup or maintenance by customer
- Apps – All apps included in Message Suite:
 - Equipment Management: Change messages and settings remotely, monitor sign online
 - Image Management: Online image retrieval and management of images from internal camera
 - Alerts: Notifications for low battery and tampering, alerts can include images
 - Mapping: Visually manage equipment and data
 - Premier Care Perpetual Warranty

ATS PC Sign Manager: Local Management using PC with USB connection standard with all signs

- PC based client software
- Connect to sign via USB or Bluetooth(optional)

ATS Android App: Local Management (*Optional*):

- Android OS wireless Bluetooth control local to unit
- Android device can be phone or WiFi device with Bluetooth

Local Management Features:

- Create and change messages, modes and settings
- Local image retrieval and management from internal camera
- Manage all unit settings, automatic sync with TraffiCloud Web Based Management
- All traffic data and messages can be saved for online management and backup with optional TraffiCloud Message Suite
 - Create message and save to TraffiCloud library, messages available on all ATS Android App or PC Sign Manager devices
- Sign firmware field and remotely upgradeable

instALERT Settings

- Configure the following parameters via PC, Android or TraffiCloud Web-Based Management System:
 - load instaMESSAGE using “Display Now” feature
 - load 24 messages into sign’s memory
 - Scroll messages in sign’s memory
 - Display signs from server or local device memory
 - Set sign mode
 - Upload schedule

Product Specification instALERT Rapid Messenger Variable Message Sign

- Set automatic dimming range minimum and maximum levels or manually override display brightness
- Internal real time clock, time maintained with power disconnected
- Set time via local device or sync with cell signal

Scheduling

- All days, multiple messages: schedule up to 50 different messages or modes for up to 13 different time periods in a 24 hour day, repeats in each 24 hour cycle
- 7 day, multiple messages: schedule different messages or modes for up to 13 different time periods in each 24 hour day for each of 7 days, repeats in each 7 day cycle; up to 50 different messages can be used over the 7 day period
- All messages and scheduling reside on the sign – no external hardware necessary
- Program schedule via TraffiCloud Web, ATS Android App or ATS PC Sign Manager, Save to load onto multiple signs
- Camera activation controlled in schedule windows
- Internal real time clock, time and schedule maintained with power disconnected

Data Logging Option for instALERT units with the optional internal radar option – SpeedAlert 24

- Upgrade to the SpeedAlert 24, adding traffic radar to the instALERT to enable collection of traffic data and speed display functionality.
- See the SpeedAlert 24 Specification Sheet

instALERT Sign Power

- Power Input, Max:
 - 12VDC, 8A max, 96 W max; 4A, 48W typical
- Power saving circuitry and automatic dimming for ambient light conditions with adjustable dimming range and manual display brightness override
- SpeedAlert 24 Power:
 - 12VDC locking plug, 30A capacity: Compatible power supplies include:
 - o Vehicles’ power port, with optional adapter
 - o Trailer wiring adapter for hitch mount
 - o POWERcase portable power supply, PC26 or PC36
 - o 120 or 220 VAC Power supply in NEMA 4 enclosure
 - o ATS 5 Trailer (batteries with optional solar assist: 235 or 470 Ah, 60W solar option)
 - o Pole battery box: 156Ah battery with solar assist
- Battery level indicator on sign, ATS Android App, ATS PC Sign Manager or TraffiCloud Remote Management.
- Auto recovery for battery with solar
- Power cable customer replaceable, gold plated connector contacts, high visibility yellow cable



Product Specification instALERT Rapid Messenger Variable Message Sign

Standard instALERT System Components

- instALERT Variable Message Sign iA24
- ATS PC Sign Manger software with USB cable
- On-Board Controls

instALERT Mounting Options

- ATS 5 Trailer (refer to ATS 5 specifications for more info)

Options using the instALERT mounting bracket

- Hitch mount
 - Sign height: 25" to bottom, 53" to top of sign from receiver tube (final height dependent on receiver height, flip mounting bracket for an additional 12")
 - Fits 1 1/4" or 2" receiver, adapter included
 - 1/2" hitch pin
 - Locking rotation adjustment on 15 degree increments over 180 degrees,
 - +/- 5 degrees tilt to adjust LED aim for maximum brightness
 - White powder coat finish with rear reflector
 - Not intended for operation above 15 MPH
- Telescoping Hitch Mount
 - All features of standard hitch mount, plus
 - Sign height: 53" to bottom, 81" to top of sign from receiver tube (final height dependent on receiver height, flip mounting bracket for an additional 12")
- Standard Folding Portable Post:
 - Folds for easy storage and portability
 - 42" to 55" to bottom, 70" to 83" to top of sign depending on leg positions, rotate bracket for additional 12"

Optional instALERT Sign Components and Features

- TraffiCloud Web-Based Remote Management Service
- ATS Android App, Bluetooth connectivity
- Padded carrying case with accessory pockets, shoulder strap
- Mounting bracket
 - mounts to pole or any surface using any hardware, no tools required
 - tamper resistant hardware compartment
 - rotate bracket for additional 12" of mounting height
 - aluminum with black powder coat
 - sign can be locked into bracket
 - bolt sign to mounting bracket for additional security
 - Mounting hardware supplied
- Internal radar allowing for speed display, speed dependent messaging and speed and volume data collection - SpeedAlert 24
- Drive Times sensor-free Time to Destination Service – Travel time data sent to sign every minute

Warranty

- 1 year warranty (3 months on Li-Ion batteries)

- Premier Care
 - Extended Warranty
 - Product software upgrades free
 - Vandalism and accidental damage (non-warranty) at 50% off list price

Made in the United States of America



instALERT 24
on ATS-5



instALERT 24
on
Portable Post



Product Specification instALERT Rapid Messenger Variable Message Sign

instALERT Dimensions, Open

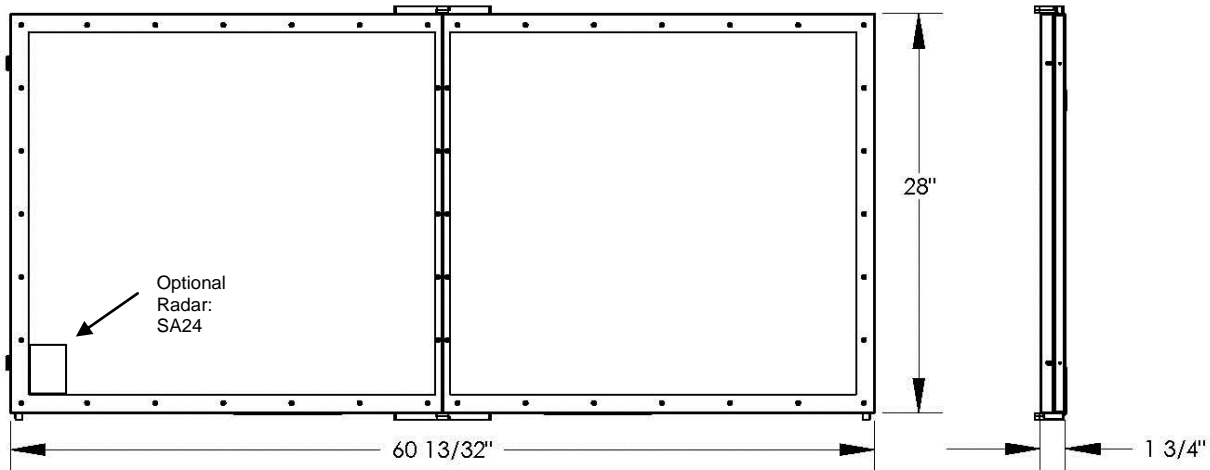

instALERT Dimensions, Folded

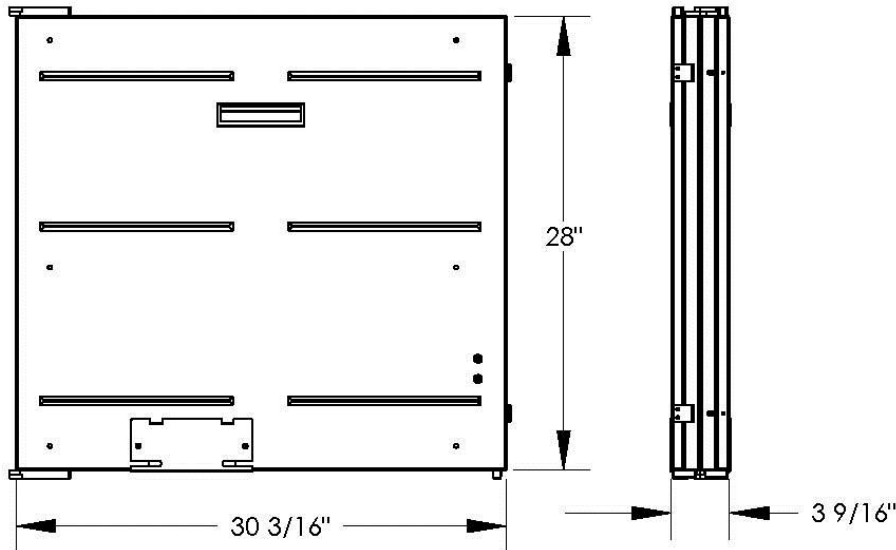

Mounting Plate Dimensions

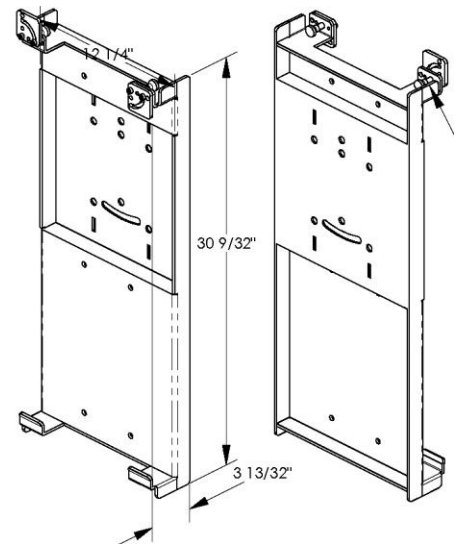

Mounting Hole Positions

